

Drehfix basement drain DN 100, Black grating, Type 5

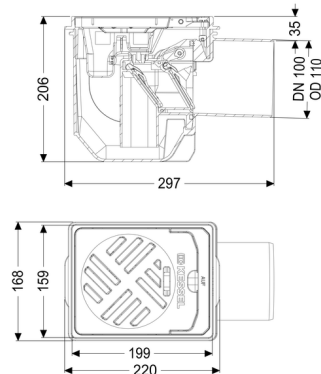
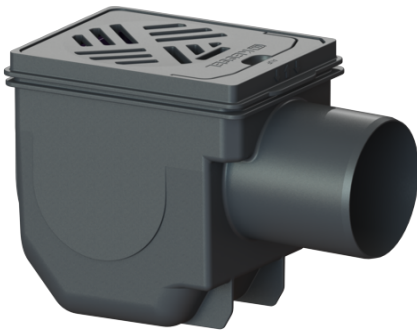

Article information

Item no.: 27301
 GTIN: 4026092007815
 Price group: 10

Advantages

- Integrated backwater protection
- Simple
- toolless maintenance and cleaning
- Ideal for modernisation: compact installation dimension makes installation in the recess of old cast iron drains possible

Description

The basement drain for faecal-free wastewater is equipped with two mechanical flaps which close automatically in the event of backwater. One flap serves at the same time as an emergency closure to be closed by hand.

Type of wastewater: wastewater without sewage
 Installation situation: floor slab installation

Version:

Odour trap: included
 Emergency closure: yes
 Delivery state: installation-ready
 Backwater protection: Type 5
 Number of mechanical backwater flaps: 2

General characteristics:

Nominal size (DN): 100
 Outer diameter (OD): 110
 Colour: black

Standard: EN 1253, EN 13564

Dimensions:

Length: 285 mm
Width: 168 mm
Cutout dimension, length: 320 mm
Cutout dimension, width: 190 mm

Tank:

Installation depth: 210 - 240 mm
Vertical adjustment: vertically adjustable upper section

Coverage features:

Type of cover: Slotted cover
Colour of cover: black
Load class: K 3 (EN 1253-1)
Sludge bucket: yes

Grating:

Grating colour: black
Grating material: Polymer
Grid size, width: 150 mm
Grid size, height: 14 mm
Grid size, length: 190 mm

Discharge rate (l/s) with 20 mm backwater: 1.8 l/s