

## Pumping station Aquapump XXL Duo, STZ 5200-S1

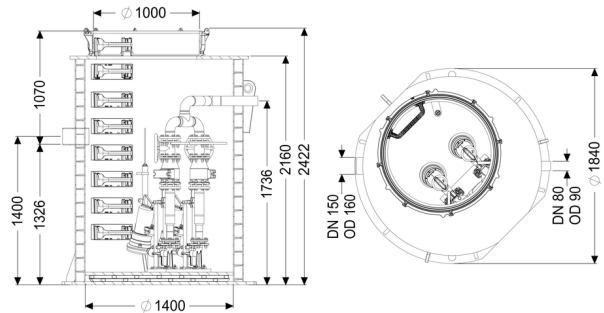

### Article information

Item no.: 8743040  
 GTIN: 4026092078082  
 Price group: 60

### Description

Type of wastewater: wastewater with sewage  
 Installation situation: underground installation

### Version:

Type of system: Twin pump station  
 Installation: Wet installation  
 Shut-off valve: Shut-off valve made of cast iron  
 Pump control: Control unit  
 Backflow preventer: integrated  
 Access steps: yes  
 Note on installation depth: in combination with a chamber module  
 Passage seal for ventilation pipe (DN): 100 mm  
 Passage seal for conduit pipe (DN): 100 mm

Delivery state: Pre-mounted for final assembly on site (pumps and sensor system must be fitted on site and control unit must be connected)

### General characteristics:

Colour: black  
 Standard: EN 12050-1

**Dimensions:**

|         |          |
|---------|----------|
| Length: | 1,880 mm |
| Width:  | 1,880 mm |
| Height: | 2,440 mm |

**Tank:**

|  |                                      |
|--|--------------------------------------|
| Number of inlets:                                      | 1 ST                                 |
| Inlet nominal size (DN):                               | 150                                  |
| Inlet nominal size (OD):                               | 160 mm                               |
| Distance pipe bottom inlet to tank bottom:             | 1,320 mm                             |
| Distance from centre of outlet pipe to tank bottom:    | 1,735 mm                             |
| Distance from centre of inlet pipe to tank bottom:     | 1,400 mm                             |
| Pumping volume:  | 800 l                                |
| Pressure pipe connection:                              | horizontal                           |
| Pressure pipe connection (DN):                         | 80 mm                                |
| Pressure pipe connection (OD):                         | 90 mm                                |
| Groundwater resistant from lower edge of base section: | 3,000 mm                             |
| Clear width of tank (LW):                              | 1,600 mm                             |
| Clear width of entry (LW):                             | 1,000 mm                             |
| Chamber system:  | Twin walled re-enforced pipe chamber |

**Pumping device:**

|  |                                      |
|--|--------------------------------------|
| Pump:  | STZ 5200                             |
| Number of pumps:                                   | 2                                    |
| Max. pumping capacity:                             | 21.3 m <sup>3</sup> /h               |
| Max. pumping height:                               | 52 m                                 |
| Operating mode:                                    | S1                                   |
| Power P1:  | 5.2 kW                               |
| Power P2:  | 4.4 kW                               |
| Speed:   | 2,840 U/min                          |
| Max. temperature (permanent) of conveyed material: | 40 °C                                |
| Connection type:                                   | Direct connection                    |
| Weight:  | 56 kg                                |
| Impeller type:                                     | Macerator                            |
| Length of mains cable for pump:                    | 10 m                                 |
| Rated current:                                     | 8.7 A                                |
| Protection class (pump):                           | IP 68 (20m)                          |
| Protection class:                                  | I                                    |
| Type of pump connection cable:                     | H07RN8-F PLU 10G 1.5 mm <sup>2</sup> |
| Temperature monitoring:                            | integrated                           |
| Cos phi - power factor:                            | 0.89                                 |

Insulation class: H

### Control:

|  |              |
|--|--------------|
| Control unit:                                  | Comfort Plus |
| Operating voltage:                             | 400 V        |
| Mains frequency:                               | 50 Hz        |
| Self-diagnosis system (SDS):                   | yes          |
| Battery buffering:                             | yes          |
| Multi-line display:                            | yes          |
| Log book function:                             | yes          |
| USB interface:                                 | yes          |
| GSM interface:                                 | yes          |
| Potential-free contact:                        | yes          |
| Type of fuse required (electrical protection): | 3 x C 32 A   |
| Motor protection switch:                       | yes          |
| Protection class control unit:                 | IP 54        |
| Length of mains cable for control unit:        | 0 m          |
| Type of level measurement:                     | hydrostatic  |
| Level measurement instrument:                  | Level sensor |
| Alarm sensor:                                  | Level sensor |