

## Oil-/fuel separator *EasyOil* ground NS 3 – 20, class II

for underground installation with DIBt-certification



DIN 1999-100 DIN 1999-101 Z-83.8-55

Made of polyethylene

### Installation

- Installation is possible with groundwater up to the upper edge of the tank (UET)
- A load distribution plate must be planned for class D
- Class D = 700 mm ≤ DEC ≤ 1500 mm  
Class A / B = 700 mm ≤ DEC ≤ 1800 mm

### Consisting of:

Upper sections made of polymer, continuous height and level adjustment, tiltable to 5°, with covers class A / B, D according to EN 124 in cast iron (can be driven over by cars and trucks), incl. lift-out key. Inlet and outlet Ø ... for synthetic material pipes in: PE-HD (according to EN 12666-1); PVC pipe (according to EN 1401-1); PP or AS.

### Note:

- Suitable for filling stations with high-performance filling pumps, E10 and biodiesel fuels
- Choose separator size and article number from table below.

Contact KESSEL for separator sizing support if required

- **Accessories:** Sampling chamber for underground installation, extension section for deep installation, alarm units for when the maximum oil level is reached and there is a back-up of water (required according to EN 858 Part 1), oil and sludge suction system, coalescence filter insert for retrofitting to the coalescence separator, *SonicControl* page 397 – 399, pumping stations see chapter "3"

- **Technical note:** page 394

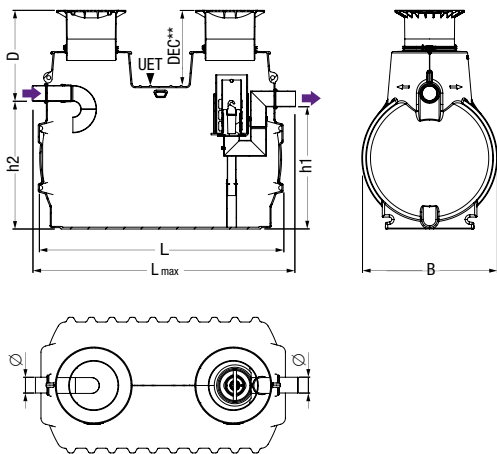
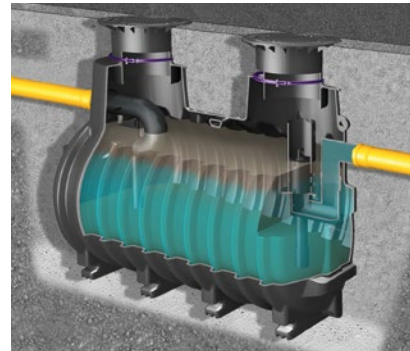

NS	Installation depth D (min/max) in mm	Art. no.
<b>Cover class A / B</b>		
NS 3	710 - 1170	99 403.10B EX
NS 6	735 - 1195	99 606.30B EX
NS 6	735 - 1195	99 606.80B EX
NS 10	710 - 1170	99 610.15B EX
NS 10	735 - 1195	99 610.30B EX
NS 10	735 - 1195	99 610.80B EX
NS 15	735 - 1195	99 615.80B EX
NS 20	735 - 1195	99 620.80B EX
<b>Cover class D</b>		
NS 3	710 - 1170	99 403.10D EX
NS 6	735 - 1195	99 606.30D EX
NS 6	735 - 1195	99 606.80D EX
NS 10	710 - 1170	99 610.15D EX
NS 10	735 - 1195	99 610.30D EX
NS 10	735 - 1195	99 610.80D EX
NS 15	735 - 1195	99 615.80D EX
NS 20	735 - 1195	99 620.80D EX

NS	Ø* (mm)	Sludge trap capacity (l)	L (mm)	B (mm)	h1 (mm)	h2 (mm)	Oil storage capacity (l)	Excess level	Weight (kg)	Total volume (l)	D-DEC	Lmax
3	160	1000	2390	1200	1070	1100	215	90	379	1800	155	2642
6	200	2500 <sup>1)</sup>	2590	1760	1600	1630	380	120	519	4300	180	2940
6	200	5000	3110	1760	1600	1630	470	130	594	5800	180	3460
10	160	1500	2910	1200	1070	1100	267	100	424	2600	155	3162
10	200	2500 <sup>1)</sup>	2590	1760	1600	1630	380	120	519	4300	180	2940
10	200	5000	3110	1760	1600	1630	470	130	594	5800	180	3460
15	200	5000	3110	1760	1600	1630	470	130	594	5800	180	3460
20	200	4000	3110	1760	1600	1630	470	130	600	5800	180	3460

\* Ø = Inlet and outlet outer diameter (mm)

<sup>1)</sup> Comparable sludge trap total volume in accordance with the dimensioning according to EN 858-2.